

# СМАРТ ПОЗИЦИОНЕРЫ SS3(L\R)



Архангельск (8182)63-90-72  
Астана (7172)727-132  
Астрахань (8512)99-46-04  
Барнаул (3852)73-04-60  
Белгород (4722)40-23-64  
Брянск (4832)59-03-52  
Владивосток (423)249-28-31  
Волгоград (844)278-03-48  
Вологда (8172)26-41-59  
Воронеж (473)204-51-73  
Екатеринбург (343)384-55-89

Иваново (4932)77-34-06  
Ижевск (3412)26-03-58  
Иркутск (395)279-98-46  
Казань (843)206-01-48  
Калининград (4012)72-03-81  
Калуга (4842)92-23-67  
Кемерово (3842)65-04-62  
Киров (8332)68-02-04  
Краснодар (861)203-40-90  
Красноярск (391)204-63-61  
Курск (4712)77-13-04  
Липецк (4742)52-20-81

Магнитогорск (3519)55-03-13  
Москва (495)268-04-70  
Мурманск (8152)59-64-93  
Набережные Челны (8552)20-53-41  
Нижний Новгород (831)429-08-12  
Новокузнецк (3843)20-46-81  
Новосибирск (383)227-86-73  
Омск (3812)21-46-40  
Орел (4862)44-53-42  
Оренбург (3532)37-68-04  
Пенза (8412)22-31-16

Пермь (342)205-81-47  
Ростов-на-Дону (863)308-18-15  
Рязань (4912)46-61-64  
Самара (846)206-03-16  
Санкт-Петербург (812)309-46-40  
Саратов (845)249-38-78  
Севастополь (8692)22-31-93  
Симферополь (3652)67-13-56  
Смоленск (4812)29-41-54  
Сочи (862)225-72-31  
Ставрополь (8652)20-65-13

Сургут (3462)77-98-35  
Тверь (4822)63-31-35  
Томск (3822)98-41-53  
Тула (4872)74-02-29  
Тюмень (3452)66-21-18  
Ульяновск (8422)24-23-59  
Уфа (347)229-48-12  
Хабаровск (4212)92-98-04  
Челябинск (351)202-03-61  
Череповец (8202)49-02-64  
Ярославль (4852)69-52-93

Россия (495)268-04-70 Киргизия (996)312-96-26-47 Казахстан (772)734-952-31

Единый адрес для всех регионов: [www.powergenex.nt-rt.ru](http://www.powergenex.nt-rt.ru) || [pgf@nt-rt.ru](mailto:pgf@nt-rt.ru)

**Sturdy explosion proof housing and smart performance with innovative and ever-strong coil drive even under harsh working environments**



## Features

- ▶ Flameproof IECEx / ATEX / TR-CU / KC Ex d IIC T6
- ▶ Easy and quick auto-calibration
- ▶ Detecting RA (reverse acting) or DA (direct acting) automatically regardless of wrong air connections
- ▶ Available to use for single or double acting without any special adjustments
- ▶ Compact design allowing to be installed on small actuators
- ▶ Providing error messages against performance failures
- ▶ Possible to test the actuator with any fixed signal under a test mode
- ▶ Programmable characteristic curve with 17 points
- ▶ Wide operating temperature range -30 ~ +75 °C
- ▶ Improved control of high-friction globe and ball valves by eliminating an overshoot and a hunting
- ▶ Low air consumption
- ▶ Providing a mounting bracket to meet IEC 60534-6-1 for linear valves
- ▶ Supporting a NAMUR mounting pattern IEC 60534-6-2 (VDI/VDE 3845) and providing a multi-size mounting bracket for rotary valves

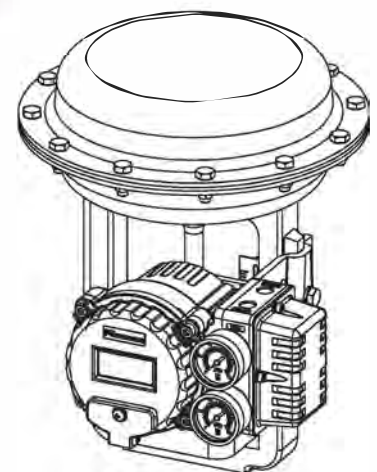

**- SS3L (Linear Type)**

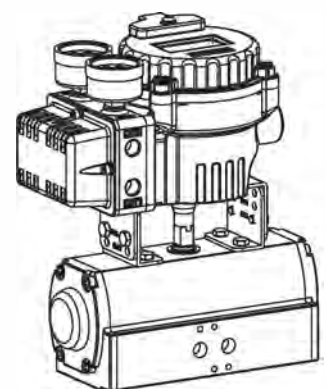

**- SS3R (Rotary Type)**

## Options

- ▶ Output position transmitter (4 - 20 mA)
- ▶ 2 x alarm limit
- ▶ Low temperature (-40°C)
- ▶ HART communication
- ▶ Profibus PA communication
- ▶ Foundation Fieldbus communication

## Specifications

Communication	Without	HART	Profibus - PA	Foundation Fieldbus
Input Signal / Bus voltage	4 - 20 mA @ 24 VDC		9 - 32 VDC	
Min. / Max. Current	3.6 mA / 50 mA		-	
Current Consumption	-		15mA	16mA
Voltage Drop (Resistance)	8.7 VDC(435Ω)	9.4 VDC(470Ω)	-	
Stroke / Angle	Linear type : 5 - 130 mm * Rotary type : 25 - 120°			
Air Supply Pressure	1.4 - 7.0 bar ( 20 - 100 psi ), filtered, compressed dry and non-oiled to meet Class 3 of ISO 8573-1			
Output Pressure Range	0 - 100% of supply air pressure			
Air Capacity	80 l/min = 4.8 N <sup>m</sup> /h = 2.8 scfm (Sup = 1.4 bar) 233 l/min = 14 N <sup>m</sup> /h = 8.2 scfm (Sup = 6 bar)			
Air Consumption	2.8 l/min = 0.17 N <sup>m</sup> /h = 0.1 scfm (Sup = 1.4 ~ 6 bar)			
Characteristic	Linearity < ±0.3% F.S Hysteresis < 0.2% F.S		Sensitivity < 0.2% F.S Repeatability < 0.2% F.S	
Performance Characteristic	Linear, EQ %, Quick open, User set (17 points)			
LCD Indication	4-digit LCD indicator			
Adjustable Speed	1 - 1000 (lowest 1, highest 1000)			
Scan Time	2ms			
Shut-off Value	Range 0 - 10% of position signal			
Valve Action	direct action (DA) / reverse action (RA)			
Operating Temperature	- 30 ~ +75°C (- 22 ~ +167 °F) **			
Pneumatic Connections	PT(Rc) 1/4 or NPT 1/4			
Electrical Connections	2 x PF(G) 1/2 , NPT 1/2 , M20 x 1.5			
Protection Class	Flameproof IECEx / ATEX / KC Ex d IIC T6, IP66			
Body Material	Aluminum die-cast / powder-painted			
Weight	2.8 kg			

\* Up to 200mm on request    \*\* -40°C on request

## Principle of Operation

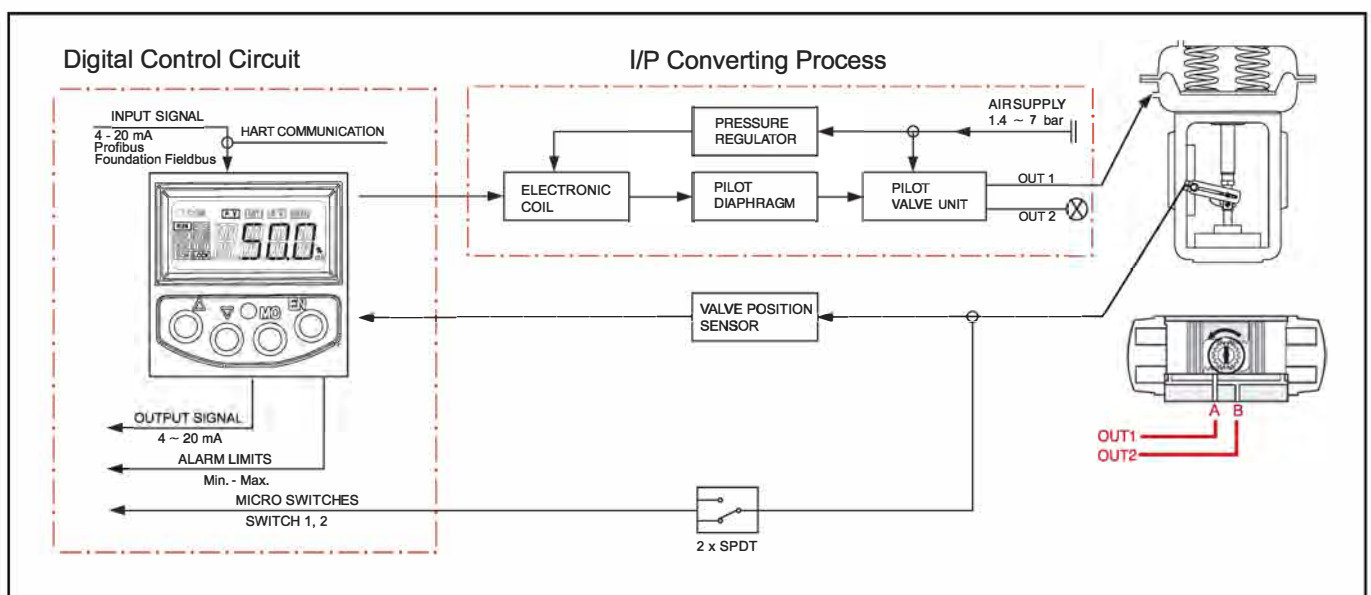

If 4-20 mA input signal (or Bus communication signal) is supplied, the micro processor compares input signal with position feedback and sends control signal to the I/P converting module. Pneumatic signal from the I/P converting module operates the valve and the valve stays at the desired position.

## Mounting to Linear Actuator

### - SS3L (Linear Type)

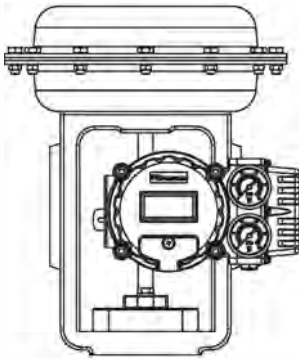

< Front View >

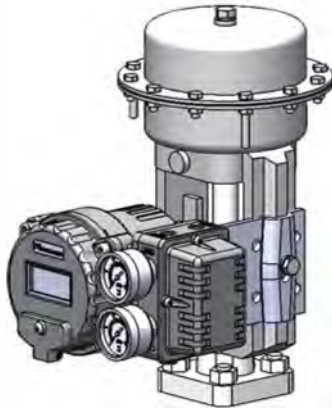

< Side View >

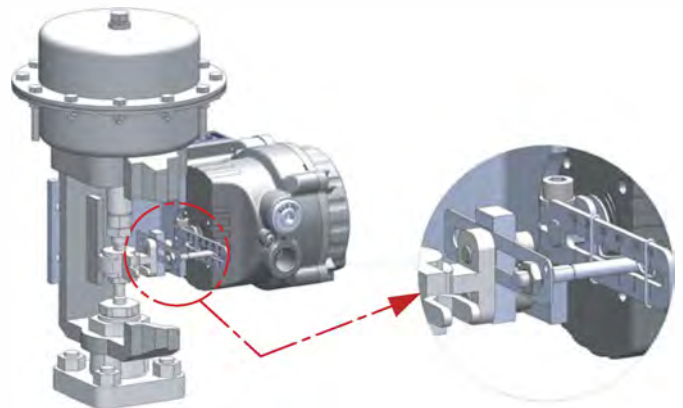

< Feedback Lever Connection >

#### "A" Type

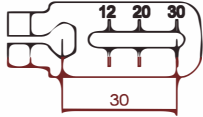

#### "B" Type

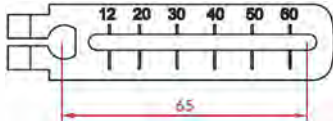

#### "C" Type

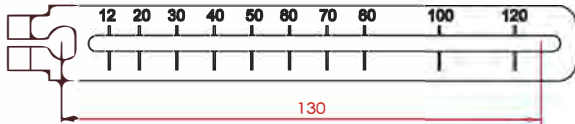

Feedback Lever

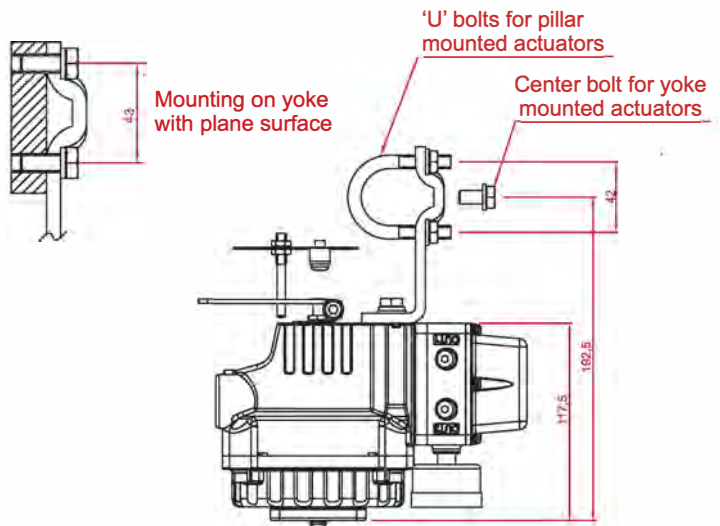

Mounting to linear actuators to IEC 60534 6-1

## Mounting to Rotary Actuator

### - SS3R (Rotary Type)

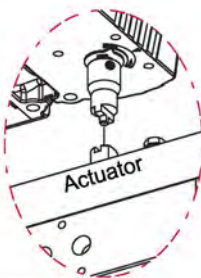
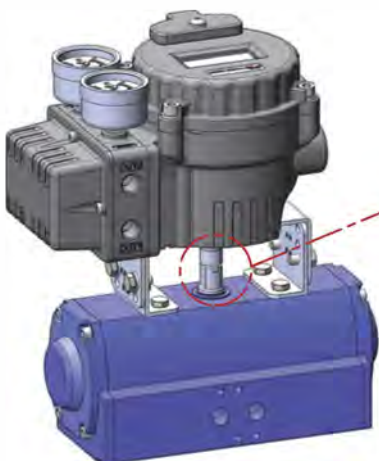

**NAMUR Type Mounting**  
( VDI/VDE 3845,  
IEC 60534-6-2 )

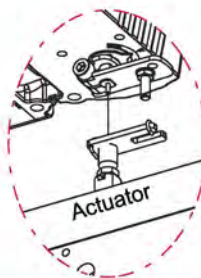

**Fork Lever Type Mounting**

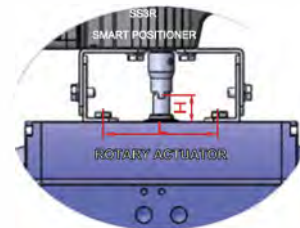

#### Size Variation of Multi-Size Bracket

- 1) 80 x 30 x 20 (H) , 4) 130 x 30 x 20 (H)
- 2) 80 x 30 x 30 (H) , 5) 130 x 30 x 30 (H)
- 3) 80 x 30 x 50 (H) , 6) 130 x 30 x 50 (H)

H : Rotary Actuator Shaft Height  
L : Length ( 80 or 130mm )

## Air Connections

### - SS3L (Linear Type)

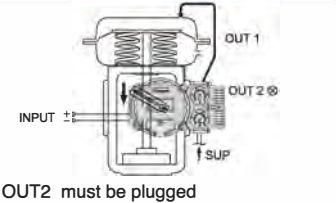
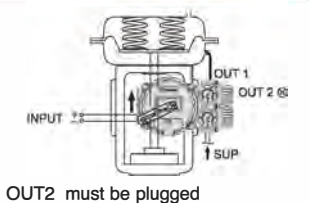
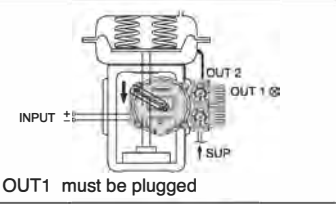
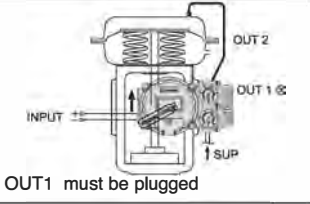
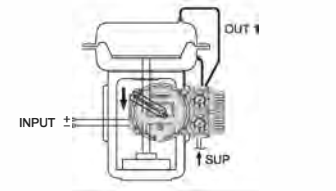
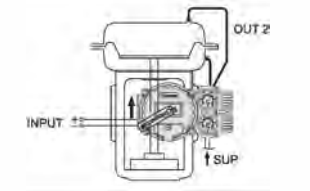
Direct Acting (DA)		Reverse Acting (RA)	
<p><b>DA 1</b></p> <p>As the input signal increases, Valve stem moves downwards Actuator : DA</p>	 <p>OUT2 must be plugged</p>	<p><b>RA 1</b></p> <p>As the input signal increases, Valve stem moves upwards Actuator : RA</p>	 <p>OUT2 must be plugged</p>
<p><b>DA 2</b></p> <p>As the input signal increases, Valve stem moves downwards Actuator : DA</p>	 <p>OUT1 must be plugged</p>	<p><b>RA 2</b></p> <p>As the input signal increases, Valve stem moves upwards Actuator : RA</p>	 <p>OUT1 must be plugged</p>
<p><b>DA 3</b></p> <p>As the input signal increases, Valve stem moves downwards</p>		<p><b>RA 3</b></p> <p>As the input signal increases, Valve stem moves upwards</p>	

### - SS3R (Rotary Type)

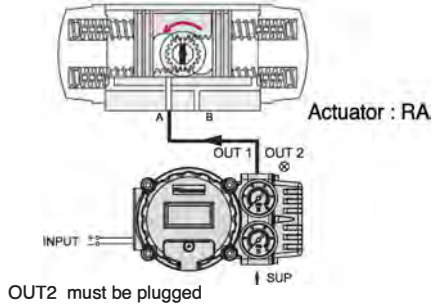
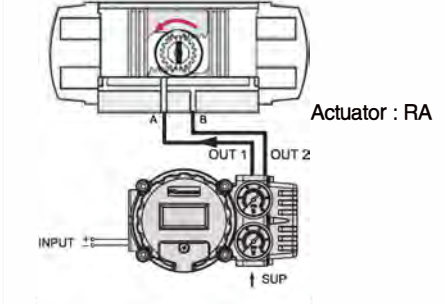
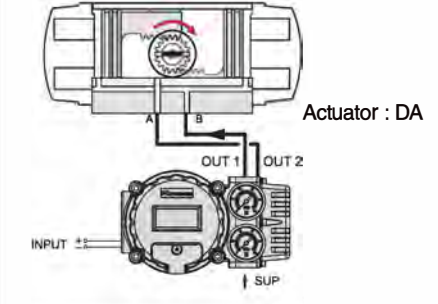
Spring Return	Double Acting	Double Acting
 <p>Actuator : RA</p> <p>OUT2 must be plugged</p>	 <p>Actuator : RA</p>	 <p>Actuator : DA</p>
<p>As the input signal increases, Actuator shaft rotates counter-clockwise</p>	<p>As the input signal increases, Actuator shaft rotates counter-clockwise</p>	<p>As the input signal increases, Actuator shaft rotates clockwise</p>

	Spring Return	Double Acting
Reverse Acting	Out 1 : piped, Out2 : plugged	Out 1 : piped to Actuator port A, Out2 : piped to Actuator port B
Direct Acting	Out 1 : plugged, Out2 : piped	Out 1 : piped to Actuator port B, Out2 : piped to Actuator port A

## SS3 Front Cover Removed

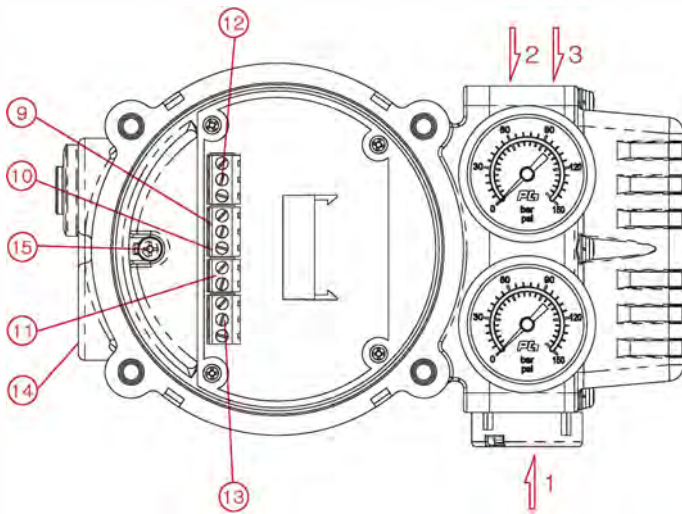

## SS3 Front Cover

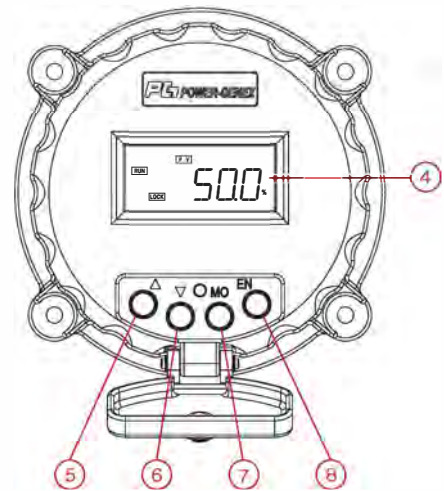

- 1 : Air supply
- 2 : OUT 1
- 3 : OUT 2
- 4 : Display LCD

- 5 : Up key
- 6 : Down key
- 7 : Mode key
- 8 : Enter key

- 9 : Input signal (+, -)
- 10 : Frame ground
- 11 : Output signal (+, -)
- 12 : Alarm limit

- 13 : Alarm limit
- 14 : Electrical connections
- 15 : Ground
- 16 : Feedback lever

## Electrical Connections

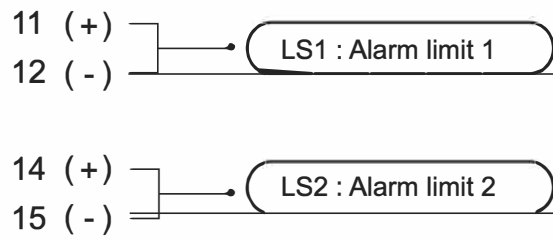
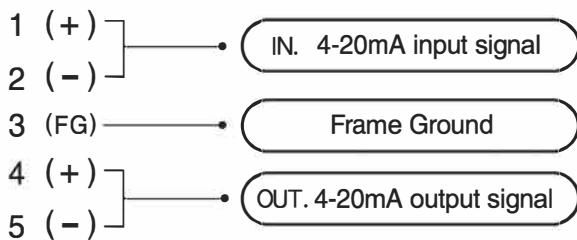

## Characteristic Curves

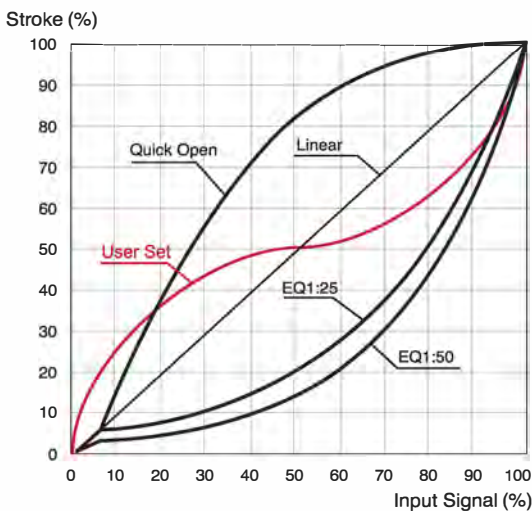

## Quick Start and Checking

	Button	Action
Auto - Calibration	MO	Push 5 seconds for auto-calibration
Span	VDN → ENT or VDN → ΔUP ENT → MO	Push VDN 5 seconds to change a measured span (Try this option only when a valve doesn't reach a desired position)
Ambient Temp.	ENT	Confirm an ambient temperature surrounding this smart valve positioner

## Parameters Diagram

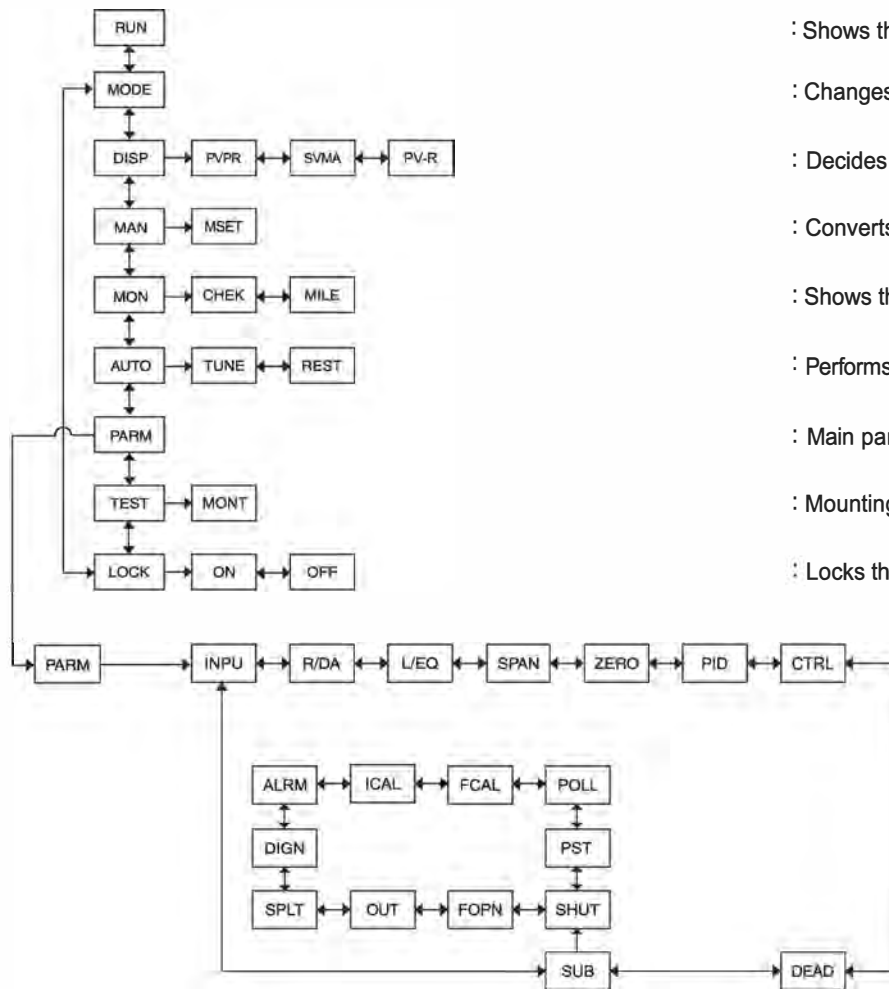

- : Shows the operating situation of the positioner
- : Changes the parameters
- : Decides LCD display mode in mA, % or a reverse way
- : Converts to the manual mode
- : Shows the selected parameters and a total valve runtime
- : Performs auto-calibration and resets all programmed values
- : Main parameters
- : Mounting test mode
- : Locks the set values

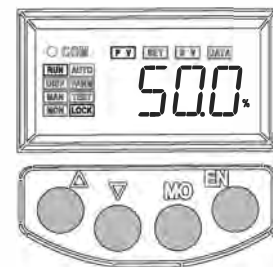

**LCD Display**

● COM : Hart Communication

Parameter	Description	Fcution	Default
INPU	Input signal	4 ~ 20mA or 20 ~ 4mA	4 ~ 20mA
R/DA	RA/DA	Reverse acting or direct acting	Auto-set
L/EQ	Characteristic	Linear, E.Q.%(1:25 or 1:50), Quick open or User set(17points)	Linear
SPAN	Span adjustment	0 ~ 100%	100%
ZERO	Zero adjustment	0 ~ 99%	0%
PID	P-GN / I-GN / D-GN	Proportional / Integral / Differential gain value	Auto-set
SPED	Response speed	1 ~ 1000	1000
SWST	Slow start	Smooth operation (ON or OFF)	Auto-set
CNLT	Control limit	50 ~ 1250	Auto-set
GCNL	Gap control limit	50 ~ 1250	Auto-set
DEAD	Dead band	0 ~ 9.99%	0.5%
FDGN	D-gain setting for hard mode	D-Gain setting for hard mode	Auto-set
C/MD	NORM / HARD / SMAL	Standard actuator, strong valve packing friction, small actuator	NORM
SHUT	Shut-off	0 ~ 9.9%	0.3%
FOPN	Full-open	0 ~ 9.9%	0.3%
OUT	Output signal	4 ~ 20mA or 20 ~ 4mA	4 ~ 20mA
SPLT	Split range	4 ~ 12mA or 12 ~ 20mA	4 ~ 20mA
DIGN	Display place	Movement to one or two decimal places	1
ALAM	Alarm limit low, high	AL1L / AL1H / AL2L / AL2H	0 ~ 10%, 90 ~ 105%
ICAL	IN4M / IN20	Internal match with 4~20mA input signals from a calibrator	Factory setting
FCAL	FB4M / FB20	Internal match with 4~20mA output signals to a calibrator	Factory setting
POLL	Polling address	HART Communication polling address (0 ~ 15)	0
PST	Partial stroke test	Checks a valve status	OFF

## Wiring Alarm Limits

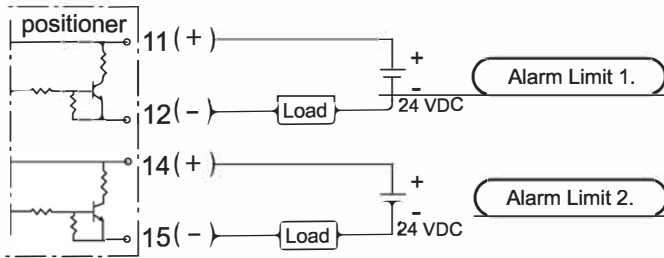

Note that 24 VDC should be supplied for power.

## Micro Switches (SPDT)

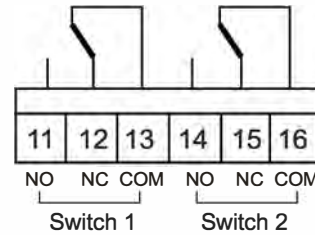

## Measuring Output Signal

① With mA loop calibrator



② With multimeter (mA)

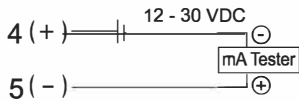

ZERO and SPAN of position feedback are automatically set after auto-calibration process.

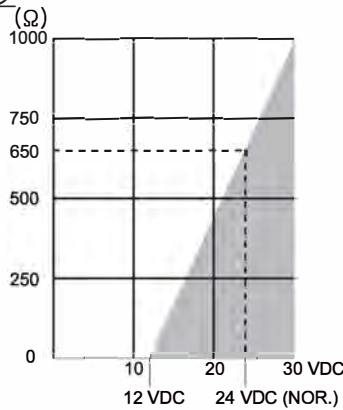

< Transmitter Load Limitations >

## Position Transmitter

Output Signal	4 - 20 mA, 2-wire
Power Supply	12 - 30 VDC
Output Current Limit	30 mA DC
Linearity	1% F.S
Operating Temp.	-30 ~ +80 °C

## How to Order

# SS3

Actuator Operation	Protection Class	Feedback Lever	Pressure Gauges	By-pass	Position Feedback	Communication	Connection Threads	Mounting Bracket	Feedback Pin Guide Lever Set
--------------------	------------------	----------------	-----------------	---------	-------------------	---------------	--------------------	------------------	------------------------------

Description	Code
<b>Actuator Operation :</b>	L : Linear type R : Rotary type
<b>Protection Class :</b>	F : Flameproof IECEX / ATEX / TR-CU Ex d IIC T6 K : Flameproof KC - Ex d IIC T6
<b>Feedback Lever :</b>	
- Linear type :	A : Stroke (5~30mm) B : Stroke (5~65mm) C : Stroke (5~130mm) D : Stroke (80~200mm)
- Rotary type :	F : Fork lever N : NAMUR shaft (direct mounting)
<b>Gauge Block :</b>	0 : Not mounted 1 : 6 bar (90 psi) 2 : 10 bar (150 psi)
<b>By-pass :</b>	N : None (standard) Y : Yes (auto/manual screw)

Description	Code
<b>Position Feedback :</b>	N : None O : Position transmitter (4~20mA output signal) L : 2 x alarm limit S : 2 x SPDT (only for rotary type) M : O + L Q : O + S (only for rotary type)
<b>Communication :</b>	N : None H : HART P : Profibus PA F : Foundation Fieldbus
<b>Connection Threads :</b> (pneumatic - electrical)	3 : PT(Rc) 1/4 - PF(G) 1/2 4 : NPT 1/4 - NPT 1/2 5 : PT(Rc) 1/4 - M20 x 1.5
<b>Mounting Bracket :</b>	N : None L : IEC 60534-6-1 (for SS3L) R : IEC 60534-6-2 (for SS3R) VDI/VE 3845
<b>Feedback Pin Guide Lever Set :</b> (only for linear type SS3L)	0 : Not included 1 : Included



## Dimensions

### - SS3L (Linear Type)

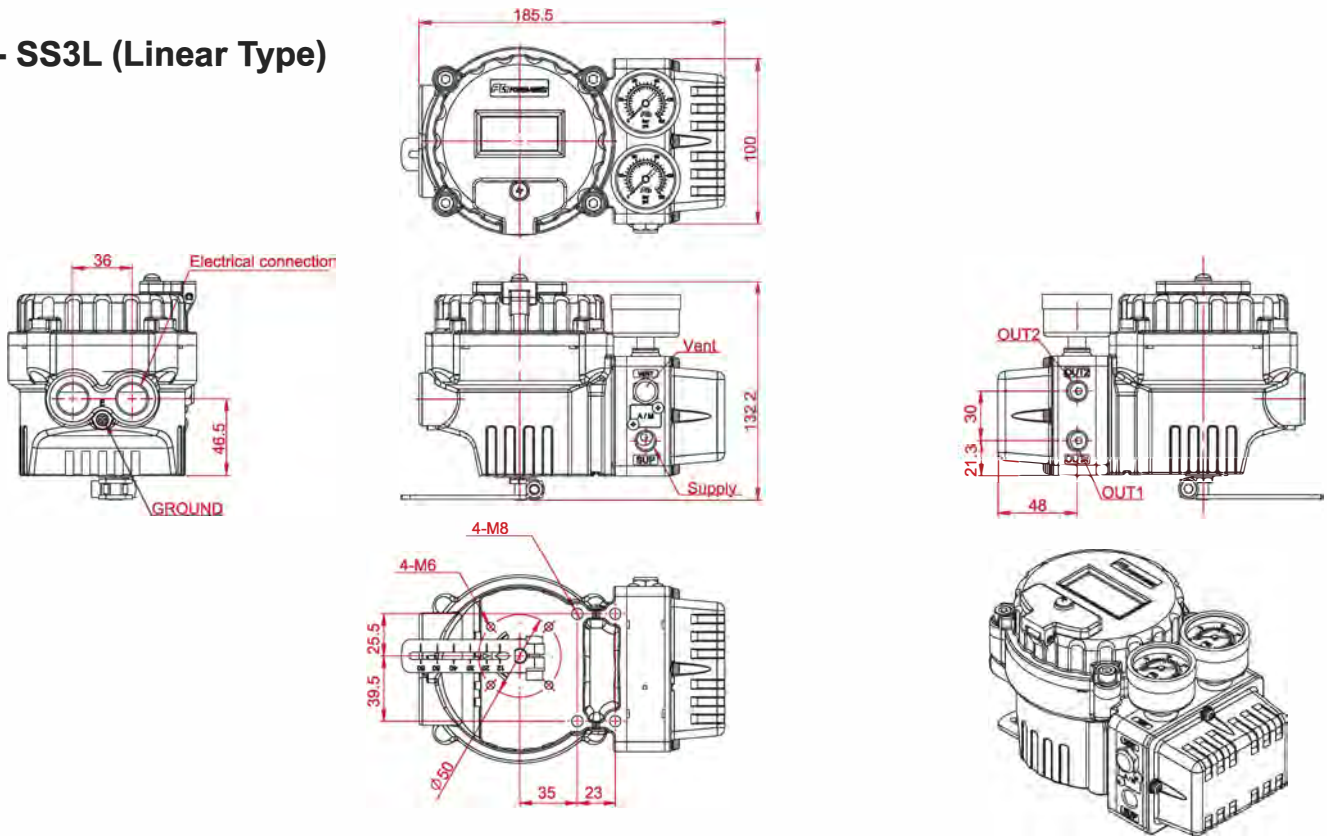

### - SS3R (Rotary Type)

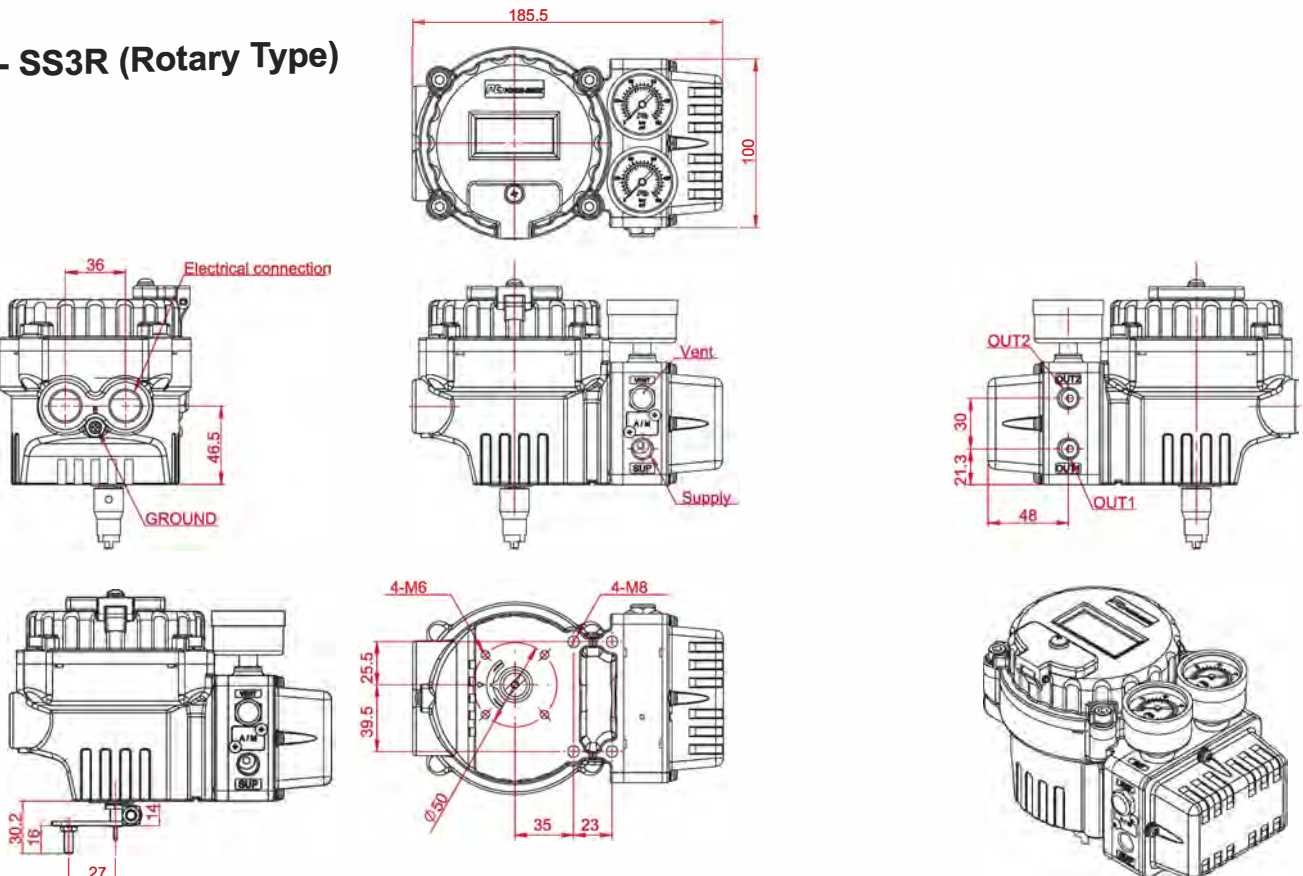

< Fork Lever Type >



Архангельск (8182)63-90-72  
 Астана (7172)727-132  
 Астрахань (8512)99-46-04  
 Барнаул (3852)73-04-60  
 Белгород (4722)40-23-64  
 Брянск (4832)59-03-52  
 Владивосток (423)249-28-31  
 Волгоград (844)278-03-48  
 Вологда (8172)26-41-59  
 Воронеж (473)204-51-73  
 Екатеринбург (343)384-55-89

Иваново (4932)77-34-06  
 Ижевск (3412)26-03-58  
 Иркутск (395)279-98-46  
 Казань (843)206-01-48  
 Калининград (4012)72-03-81  
 Калуга (4842)92-23-67  
 Кемерово (3842)65-04-62  
 Киров (8332)68-02-04  
 Краснодар (861)203-40-90  
 Красноярск (391)204-63-61  
 Курск (4712)77-13-04  
 Липецк (4742)52-20-81

Магнитогорск (3519)55-03-13  
 Москва (495)268-04-70  
 Мурманск (8152)59-64-93  
 Набережные Челны (8552)20-53-41  
 Нижний Новгород (831)429-08-12  
 Новокузнецк (3843)20-46-81  
 Новосибирск (383)227-86-73  
 Омск (3812)21-46-40  
 Орел (4862)44-53-42  
 Оренбург (3532)37-68-04  
 Пенза (8412)22-31-16

Пермь (342)205-81-47  
 Ростов-на-Дону (863)308-18-15  
 Рязань (4912)46-61-64  
 Самара (846)206-03-16  
 Санкт-Петербург (812)309-46-40  
 Саратов (845)249-38-78  
 Севастополь (8692)22-31-93  
 Симферополь (3652)67-13-56  
 Смоленск (4812)29-41-54  
 Сочи (862)225-72-31  
 Ставрополь (8652)20-65-13

Сургут (3462)77-98-35  
 Тверь (4822)63-31-35  
 Томск (3822)98-41-53  
 Тула (4872)74-02-29  
 Тюмень (3452)66-21-18  
 Ульяновск (8422)24-23-59  
 Уфа (347)229-48-12  
 Хабаровск (4212)92-98-04  
 Челябинск (351)202-03-61  
 Череповец (8202)49-02-64  
 Ярославль (4852)69-52-93

Россия (495)268-04-70 Киргизия (996)312-96-26-47 Казахстан (772)734-952-31

Единый адрес для всех регионов: [www.powergenex.nt-rt.ru](http://www.powergenex.nt-rt.ru) || [pgf@nt-rt.ru](mailto:pgf@nt-rt.ru)