

СОЛЕНОИДНЫЕ КЛАПАНЫ ESV-S, ESV-D, ESV-DS, ESV-SS



Архангельск (8182)63-90-72
Астана (7172)727-132
Астрахань (8512)99-46-04
Барнаул (3852)73-04-60
Белгород (4722)40-23-64
Брянск (4832)59-03-52
Владивосток (423)249-28-31
Волгоград (844)278-03-48
Вологда (8172)26-41-59
Воронеж (473)204-51-73
Екатеринбург (343)384-55-89

Иваново (4932)77-34-06
Ижевск (3412)26-03-58
Иркутск (395)279-98-46
Казань (843)206-01-48
Калининград (4012)72-03-81
Калуга (4842)92-23-67
Кемерово (3842)65-04-62
Киров (8332)68-02-04
Краснодар (861)203-40-90
Красноярск (391)204-63-61
Курск (4712)77-13-04
Липецк (4742)52-20-81

Магнитогорск (3519)55-03-13
Москва (495)268-04-70
Мурманск (8152)59-64-93
Набережные Челны (8552)20-53-41
Нижний Новгород (831)429-08-12
Новокузнецк (3843)20-46-81
Новосибирск (383)227-86-73
Омск (3812)21-46-40
Орел (4862)44-53-42
Оренбург (3532)37-68-04
Пенза (8412)22-31-16

Пермь (342)205-81-47
Ростов-на-Дону (863)308-18-15
Рязань (4912)46-61-64
Самара (846)206-03-16
Санкт-Петербург (812)309-46-40
Саратов (845)249-38-78
Севастополь (8692)22-31-93
Симферополь (3652)67-13-56
Смоленск (4812)29-41-54
Сочи (862)225-72-31
Ставрополь (8652)20-65-13

Сургут (3462)77-98-35
Тверь (4822)63-31-35
Томск (3822)98-41-53
Тула (4872)74-02-29
Тюмень (3452)66-21-18
Ульяновск (8422)24-23-59
Уфа (347)229-48-12
Хабаровск (4212)92-98-04
Челябинск (351)202-03-61
Череповец (8202)49-02-64
Ярославль (4852)69-52-93

Россия (495)268-04-70 Киргизия (996)312-96-26-47 Казахстан (772)734-952-31

Единый адрес для всех регионов: www.powergenex.nt-rt.ru || pgf@nt-rt.ru

1. Introduction

1.1 General Information

This instruction and operating manual contains important notices the user should observe for a personal safety as well as for prevention against damage to property. Notices concerning a personal safety are highlighted by a safety alert symbol (.

1.2 General Safety Instructions

This product was delivered out from the factory without any safety problems after a strict quality management process. In order to maintain this status and ensure a safe operation of this product, please be sure to read all safety instructions carefully described in this manual and observe safety information and symbols without exception.

1.3 Correct Usage

- ① This product can be used only for purposes specified in these instructions. If they are not definitely stated in these instructions, the user is fully responsible for all changes and retrofits to this product.
- ② This product is the electrostatic sensitive device that may be seriously damaged by voltages undetectable to a human. These kinds of voltages occur as soon as a electronic component or an assembly is touched by a person who is not grounded against a static electricity. Damage to a electronic component as a result of overvoltage cannot usually be detected immediately. It may become apparent after a long period of operation. Therefore, please make sure to avoid electrostatic charge.

1.4 Range and Responsibilities of Personnel

- ① Qualified personnel should be trained, instructed or authorized in operating and maintaining products and systems according to the safety regulations for electrical circuits, high voltages and hazardous atmosphere.
- ② For explosion proof products, they should be trained, instructed or authorized in carrying out work on electrical circuits for hazardous systems.
- ③ They should be trained or instructed in maintenance and use of proper safety equipment according to the safety instructions.
- ④ They should have a good experience to identify risks and avoid potential hazards when working with these products and systems.

1.5 Transport and Storage

Make sure that damages during delivery are prevented through proper packaging.

Products and replacement parts should be returned in their original packaging. If the original packaging is no longer available, please ensure that they should be packaged to provide sufficient protection against transport.



2. Specifications

	Single Coil		Dual Coil	
	ESV-S	ESV-SS	ESV-D	ESV-DS
Operating Air pressure	1.5 ~ 10 bar			
Supply Air Pressure (Max.)	15 bar			
Operating Voltage : Current	AC 220V : 17mA AC 110V : 55mA DC 24V : 138mA			
Voltage Tolerance	±10%			
Explosion proof class	Exd IIC T6 (KC-certified)			
Operating Ambient Temp.	-20 ~ +60°C			
Flow Capacity(Cv)	0.9			
Mounting Configuration	NAMUR or screw interface			
Pneumatic Connections	PT 1/4 or NPT 1/4			
Electrical Connections	G 1/2, NPT 1/2 or M20			
Coil Insulation Grade	Class F or H			
Duty Cycle	100%			
Material (body)	Aluminum	316SS	Aluminum	316SS
Weight	0.9Kg	1.9Kg	1.4Kg	2.5Kg

3. Part Numbering System (order code)

SOLENOID VALVE

Model No.	: ESV-S-A220P
Explosion-proof	: Exd IIC T6
Supply air (Max.)	: 15 kgf/cm ²
Rating	: AC 220V
Ambient Temp.	: -20 ~ +70°C
Serial No.	: xxxxxxxx

Made in Korea

Model No.	ESV -	x	x	x	x
Coil(s)	Single coil	S			
	Dual coils	D			
Material	Aluminum	.			
	316SS	S			
Operating Voltage	AC 220				A220
	AC 110				A110
	DC 24				D24
Connections (Pneumatic - Electrical)	Rc 1/4 - G1/2				P
	NPT 1/4 - NPT 1/2				N

4. Principle of Operation

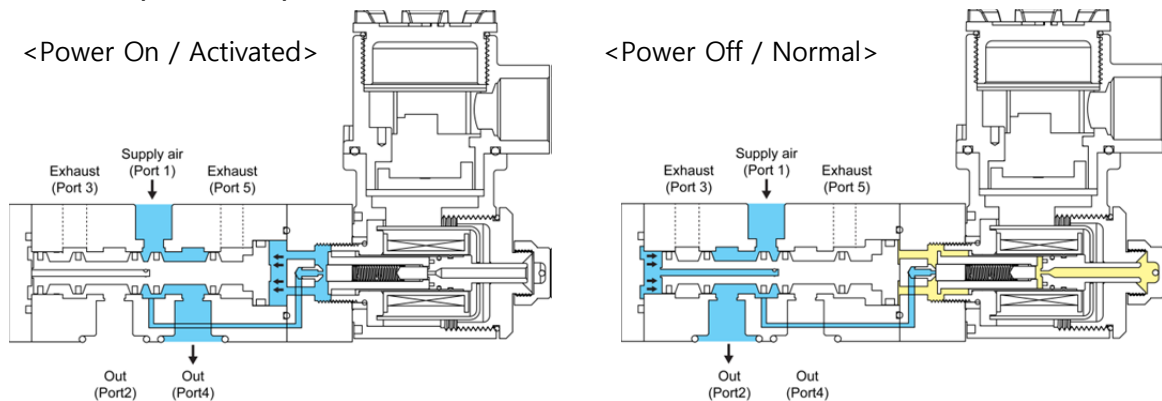

- 1) If power is on a magnetic force is created around coils.
- 2) The armature core (10) is moved to and blocks the armature vent body (20).
- 3) A supply air pushes a spool through the orifice body (3) and vents out from Port 4.
- 4) If a voltage is not supplied, a magnetic force around coils disappears.
- 5) A supply air from the orifice body (3) is blocked by a spring between the armature seat (18) and the armature core (10).
- 6) A supply air pushes the spool from the bottom through an air line at the center, and air remaining in the orifice body (3) vents out from the vent body (20).
- 7) Eventually, a supply air vents out from Port 2 when power is off.

5. Manual Switch

The ESV solenoid valve can be operated by this switch manually while air is supplied.

- Initial setting "0" : the ESV solenoid valve works with a power voltage.
- Manual operation "1" : Port 4 is open regardless of a power voltage.

When power is off and the manual switch is positioned to "0", Port 2 becomes open. When the manual switch is positioned to "1", Port 4 becomes open.

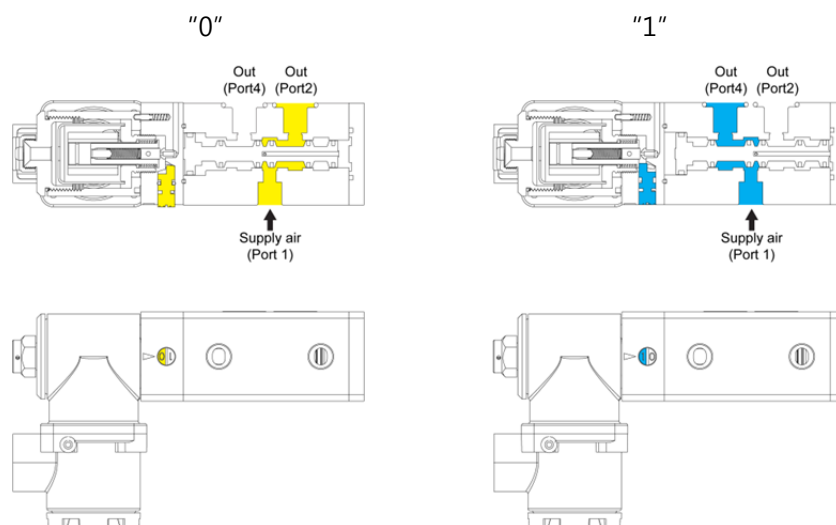

Note that the manual switch is not active when power is off.

6. Installation

As the ESV solenoid valve is designed for NAMUR mounting pattern, it can be mounted directly onto the pneumatic actuator without an additional piping. Also, as it has Rc 1/4 or NPT 1/4 threads inside of the connections as standard, the screw interface is available.

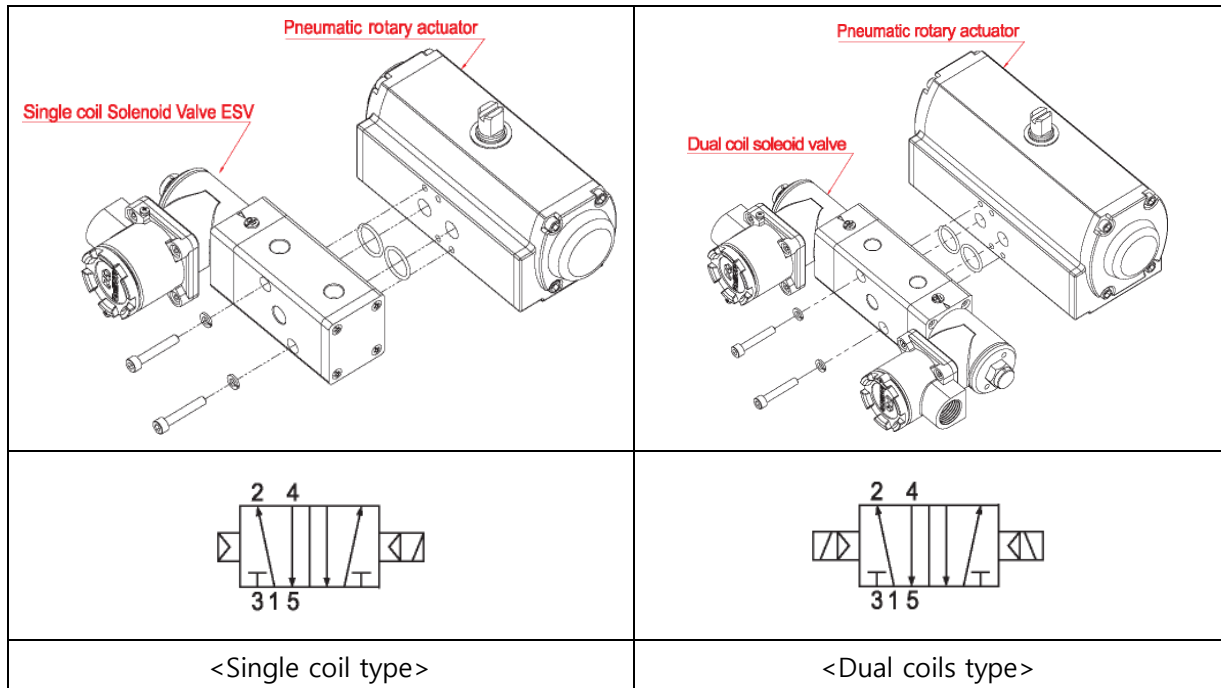

7. Electrical Connections



- ① Supply the rated voltage and current stated on this manual. Otherwise, it may cause a serious damage or malfunctions.
- ② Observe all explosion proof regulations required in the area..
- ③ Earth internally and externally before using.

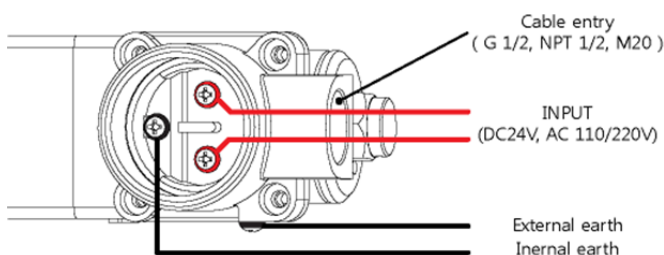

The ESV solenoid valve head can be rotated by 90° to the right or to the left for an optimal mounting as shown below.

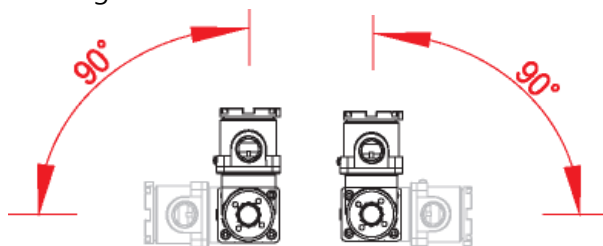

8. Spare Parts

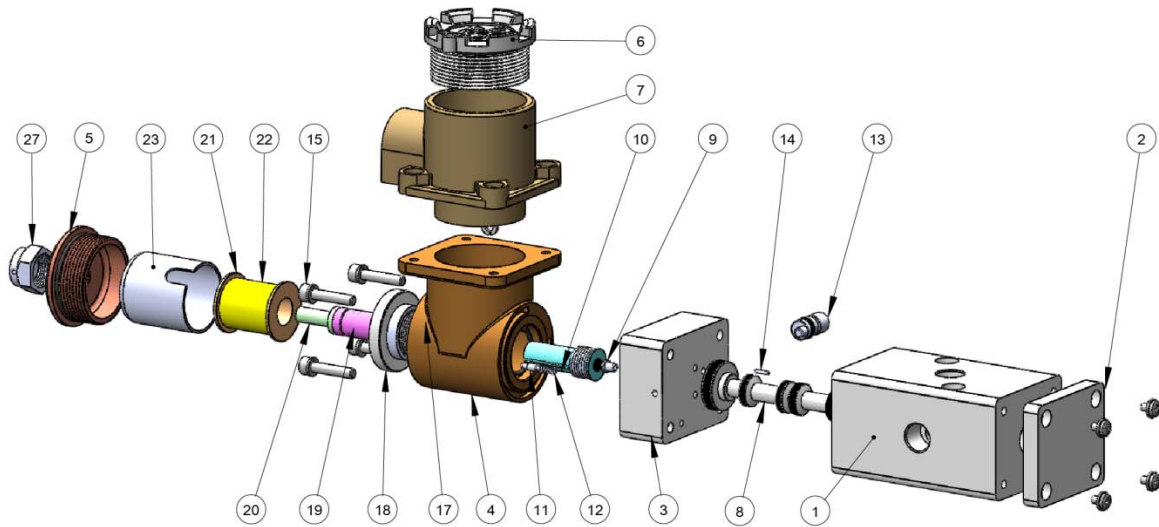

No.	Description	No.	Description
1	Valve Body	15	Orifice Body Bolt
2	Valve Body Cover	16	Valve Body Cover Bolt
3	Orifice Body	17	Armature Seat Ring
4	Coil Box Body	18	Armature Seat Bolt
5	Coil Box Cover	19	Armature Seat Tube
6	Terminal Box Cover	20	Armature Vent Body
7	Terminal Box	21	Solenoid Coil Bobbin
8	Valve Spool	22	Solenoid Coil
9	Orifice	23	Solenoid Coil Cover
10	Armature Core	25	Terminal Box Bolt
11	Stop Pin	26	Ground Bolt
12	Stop Pin Spring	27	Air Vent
13	Auto-Manual Switch		
14	Auto-Manual Switch Stop Pin		

9. Dimensions

9.1 ESV-S

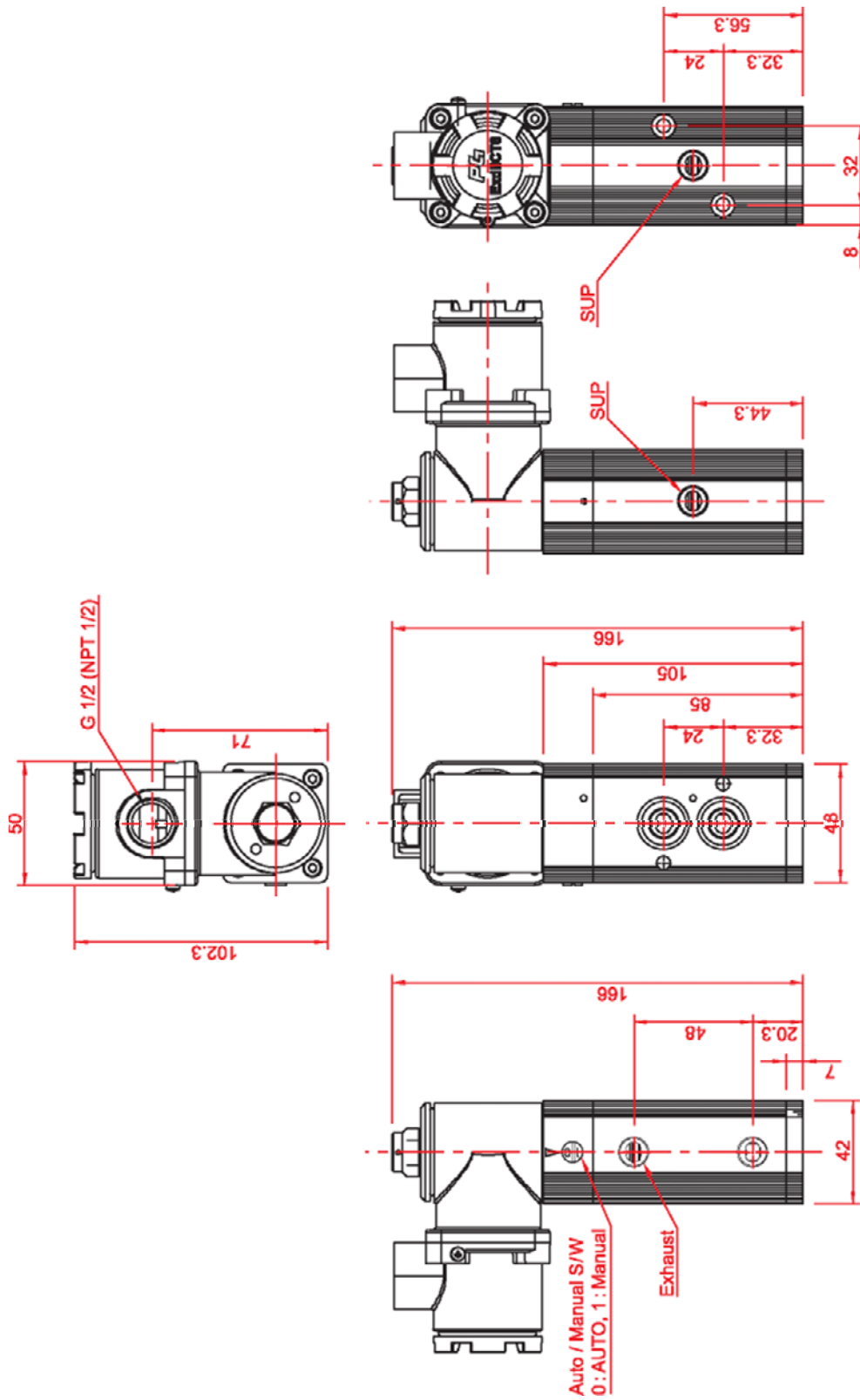

9.2 ESV-D

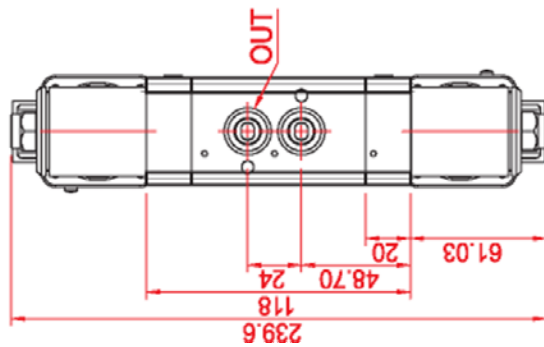
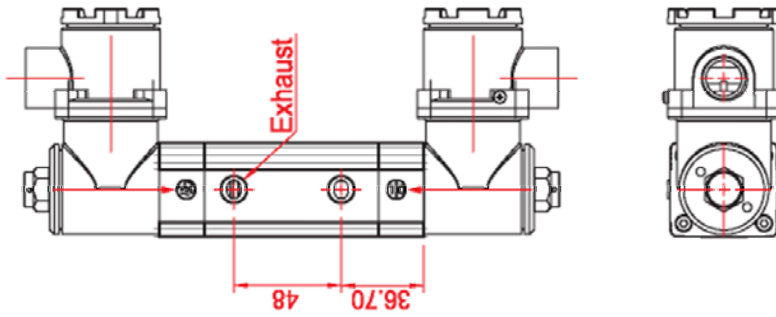
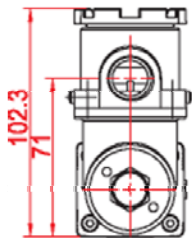
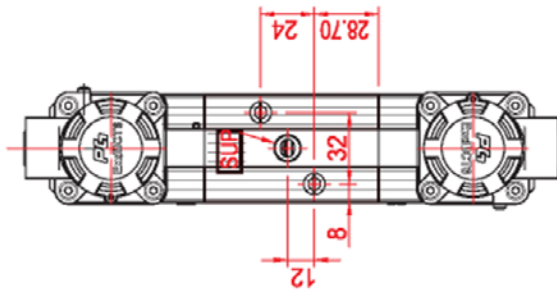
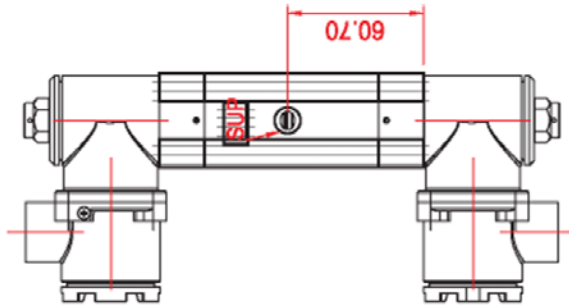



Архангельск (8182)63-90-72
 Астана (7172)727-132
 Астрахань (8512)99-46-04
 Барнаул (3852)73-04-60
 Белгород (4722)40-23-64
 Брянск (4832)59-03-52
 Владивосток (423)249-28-31
 Волгоград (844)278-03-48
 Вологда (8172)26-41-59
 Воронеж (473)204-51-73
 Екатеринбург (343)384-55-89

Иваново (4932)77-34-06
 Ижевск (3412)26-03-58
 Иркутск (395)279-98-46
 Казань (843)206-01-48
 Калининград (4012)72-03-81
 Калуга (4842)92-23-67
 Кемерово (3842)65-04-62
 Киров (8332)68-02-04
 Краснодар (861)203-40-90
 Красноярск (391)204-63-61
 Курск (4712)77-13-04
 Липецк (4742)52-20-81

Магнитогорск (3519)55-03-13
 Москва (495)268-04-70
 Мурманск (8152)59-64-93
 Набережные Челны (8552)20-53-41
 Нижний Новгород (831)429-08-12
 Новокузнецк (3843)20-46-81
 Новосибирск (383)227-86-73
 Омск (3812)21-46-40
 Орел (4862)44-53-42
 Оренбург (3532)37-68-04
 Пенза (8412)22-31-16

Пермь (342)205-81-47
 Ростов-на-Дону (863)308-18-15
 Рязань (4912)46-61-64
 Самара (846)206-03-16
 Санкт-Петербург (812)309-46-40
 Саратов (845)249-38-78
 Севастополь (8692)22-31-93
 Симферополь (3652)67-13-56
 Смоленск (4812)29-41-54
 Сочи (862)225-72-31
 Ставрополь (8652)20-65-13

Сургут (3462)77-98-35
 Тверь (4822)63-31-35
 Томск (3822)98-41-53
 Тула (4872)74-02-29
 Тюмень (3452)66-21-18
 Ульяновск (8422)24-23-59
 Уфа (347)229-48-12
 Хабаровск (4212)92-98-04
 Челябинск (351)202-03-61
 Череповец (8202)49-02-64
 Ярославль (4852)69-52-93

Россия (495)268-04-70 Киргизия (996)312-96-26-47 Казахстан (772)734-952-31

Единый адрес для всех регионов: www.powergenex.nt-rt.ru || pgf@nt-rt.ru